

SECTION A-A

**PARTS DETAIL :-**

S No.	PART NAME	MATERIAL	QTY.
1	BODY	DI	1
2	DISC	SS-316	1
3	LINER	EPDM	1
4	STEM	AST A 276 , GR SS410	1
5	BUSH	PTFE / NYLON	3
6	O-RINGS	EPDM	2
7	FASTNER	SS / MS	4

HYDROSTATIC TEST PRESSURE	
BODY (Kgf/cm <sup>2</sup> )	SEAT (Kgf/cm <sup>2</sup> )
37.5	27.5

SIZE	RATING	VALVE DIMENSIONS									MOUNTING FLANGE DETAIL		
		A	H1	H2	H3	L	ØD	FLANGE STANDARD	FACING	PCD-1	PCD	HOLE DIA	NO. OF HOLES
DN-40	PN25	33	57	125	60	182	40.5	IS:1538/BS:4505	RAISED FACE	126	50	7	4
DN-50	PN25	43	62	120	60	182	50.5	IS:1538/BS:4505	RAISED FACE	145	50	7	4
DN-65	PN25	46	72	130	60	182	65	IS:1538/BS:4505	RAISED FACE	160	50	7	4
DN-80	PN25	46	76	140	60	182	80	IS:1538/BS:4505	RAISED FACE	180	50	7	4
DN-100	PN25	52	95	160	60	182	100	IS:1538/BS:4505	RAISED FACE	210	50	7	4
DN-125	PN25	56	114	170	60	182	123	IS:1538/BS:4505	RAISED FACE	240	70	10	4
DN-150	PN25	56	126	190	60	182	148.5	IS:1538/BS:4505	RAISED FACE	275	70	10	4
DN-200	PN25	60	161	230	60	182	197	IS:1538/BS:4505	RAISED FACE	295	70	10	4
DN-250	PN25	68	215	280	60	182	250.5	IS:1538/BS:4505	RAISED FACE	358	102	12	4
DN-300	PN25	78	230	310	60	182	299.5	IS:1538/BS:4505	RAISED FACE	429	102	12	4



<b>CLIENT</b>		
<b>P.O./ENQ. NO.</b>		
<b>Model :</b>	SKS118S6G	
<b>GAD No. :</b>	19BFDT0006-08	
<b>Face to Face :</b>	BFCONCENTRIC	
<b>Valve Type :</b>		
<b>Operator:</b>	Gearbox	
		<b>SCALE</b> N.T.S
		SHEET 1 OF 1

All Dimensions are in MM unless otherwise stated.

Due to Continuous Development we reserve the rights to change in dimensions & Design keeping standard specification same.

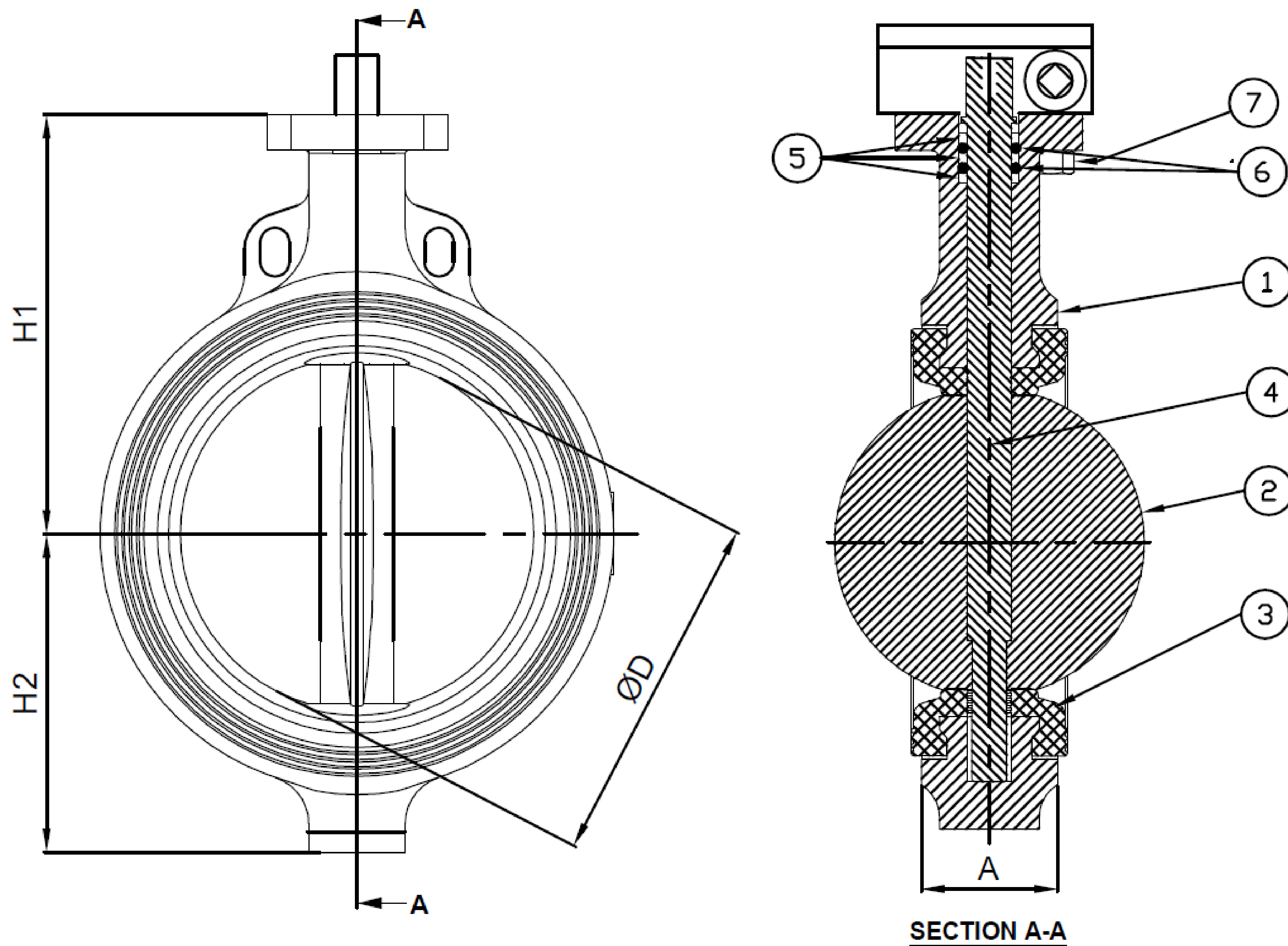

**PARTS DETAIL :-**

S No.	PART NAME	MATERIAL	QTY.
1	BODY	DI	1
2	DISC	SS-316	1
3	LINER	EPDM	1
4	STEM	AST A 276 , GR SS410	1
5	BUSH	PTFE / NYLON	3
6	O-RINGS	EPDM	2
7	FASTNER	SS / MS	4

HYDROSTATIC TEST PRESSURE	
BODY (Kgf/cm <sup>2</sup> )	SEAT (Kgf/cm <sup>2</sup> )
37.5	27.5

SIZE	RATING	VALVE DIMENSIONS							MOUNTING FLANGE DETAIL			HYDROSTATIC TEST PRESSURE	
		H1	H2	F	A	OD	FLANGE STANDARD	FACING	PCD	HOLE DIA	NO. OF HOLES	BODY (Kgf/cm <sup>2</sup> )	SEAT (Kgf/cm <sup>2</sup> )
DN-350	PN25	373	282	91	328	333	IS:1538/ BS:4505	RAISED FACE	140	18	4	24	17.6
DN-400	PN25	417	315	102	401	406	IS:1538/ BS:4505	RAISED FACE	140	18	4	24	17.6
DN-450	PN25	427	346	113	447	451	IS:1538/ BS:4505	RAISED FACE	165	22	4	24	17.6
DN-500	PN25	475	375	126	500	506	IS:1538/ BS:4505	RAISED FACE	165	22	4	24	17.6
DN-600	PN25	555	443	153	599	606	IS:1538/ BS:4505	RAISED FACE	165	22	4	24	17.6



<b>CLIENT</b>	
<b>P.O./ENQ. NO.</b>	
<b>Model :</b>	SKS118S6G
<b>GAD No. :</b>	19BFDT0006-09
<b>Face to Face :</b>	
<b>Valve Type :</b>	BFCONCENTRIC
<b>Operator:</b>	Gearbox

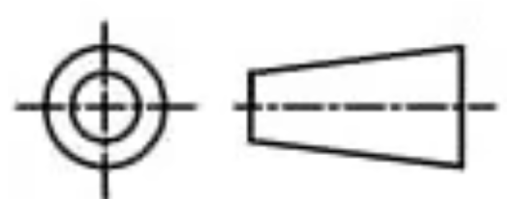

**SCALE**  
**N.T.S**

SHEET 1 OF 1

Due to Continuous Development we reserve the rights to change in dimensions & Design keeping standard specification same.

All Dimensions are in MM unless otherwise stated.