

Manual Balancing Valve Flanged

SKS 130 PN 16

PRODUCT DATA

The balancing Valve is designed for double regulating, control and shut off valve

FEATURES

- Size : DN400–DN600
- Body: Ductile Iron
- Seat: EPDM
- Connection Type: Flanged End
- Tight shut-off type
- No visible leakage

SPECIFICATIONS

- Medium Temp : -10°C to 110°C
- Medium: Water
- Nominal Pressure: PN16

STANDARDS AND CODES

- Design Std : BS 7350
- Face to Face : BS:5152
- Flange Std. : ISO 7005-2

HYDROSTATIC TEST PRESSURE

- Shell Test : 24 Bar
- Seat Test : 17.6 Bar

DIRECTION OF FLOW

- Direction of the flow is marked on the valve body by an arrow.

BALANCING VALVE

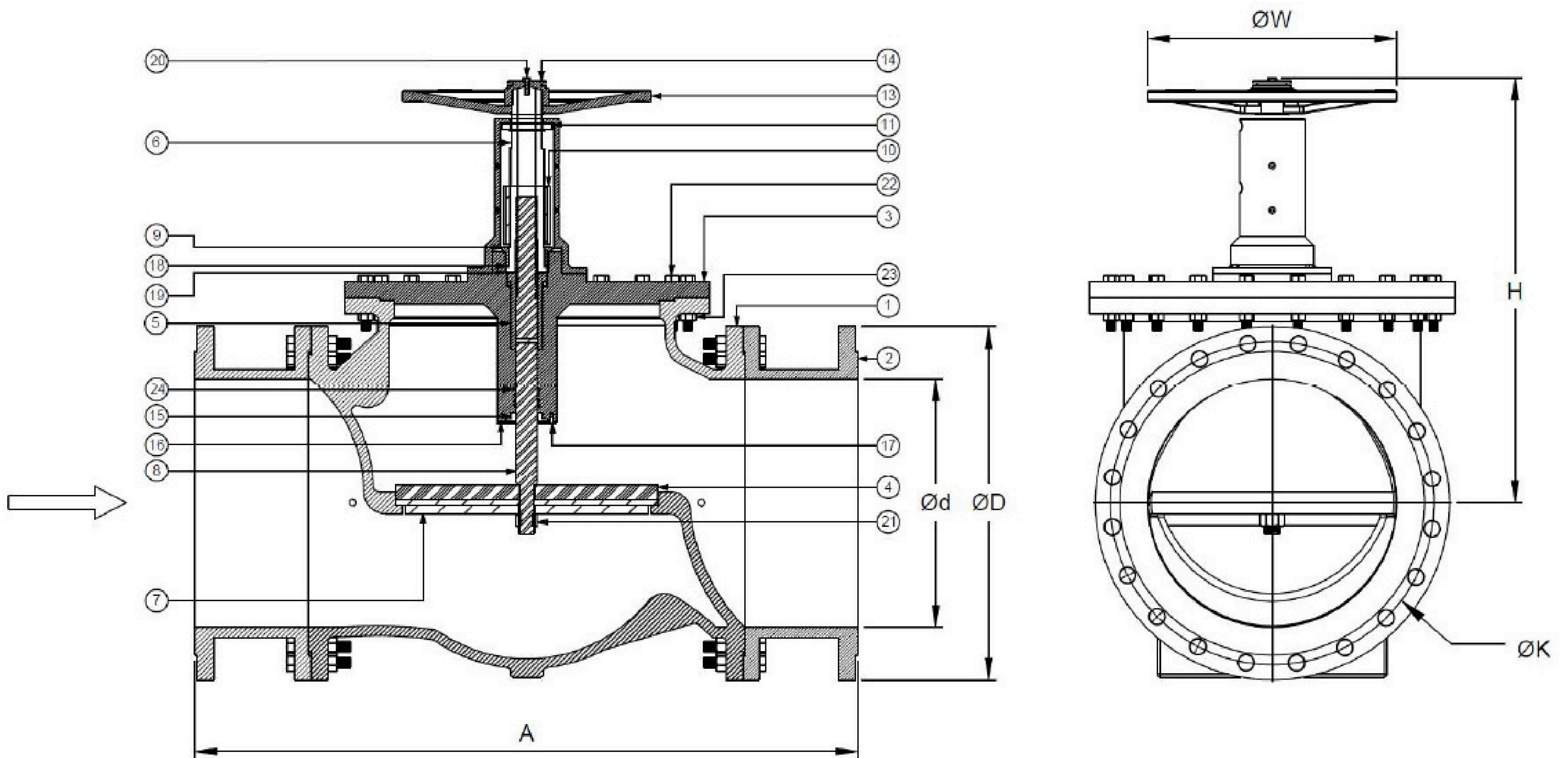

Part Descriptions

PART NO.	NAME	MATERIAL	SPECIFICATION	QTY.
1	BODY	DUCTILE IRON	IS 1865 GR. 400/15	1
2	EXTENSION	DUCTILE IRON	IS 1865 GR. 400/15	2
3	BONNET	DUCTILE IRON	IS 1865 GR. 400/15	1
4	DISC	MILD STEEL/S.S+ REPLACEABLE EPDM	IS:2062/ASTM A276 TYPE SS-304+ REPLACEABLE EPDM	1
5	GUIDE	MILD STEEL	IS2062	1
6	BALANCING NUT	MILD STEEL	----	1
7	WEIGHT PLATE	CAST IRON	IS:210 Gr. FG200	1
8	STEM	STAINLESS STEEL	ASTM A276 Gr, SS 410	1
9	CHECKNUT	BRASS	----	1
10	SCALE 1	CAST IRON	IS:210 Gr. FG200	1
11	SCALE 2	CAST IRON	IS:210 Gr. FG200	1
12	COVER	DUCTILE IRON	IS 1865 GR. 400/15	1
13	HAND WHEEL	DUCTILE IRON	IS 1865 GR. 400/15	1
14	HANDWHEEL NUT	DUCTILE IRON	IS 1865 GR. 400/15	1
15	RUBBER SEAL	RUBBER	EPDM	1
16	BONNET WASHER	STAINLESS STEEL	ASTM A276 Gr, SS 410	1
17	BONNET WASHER SCREW	STAINLESS STEEL	ASTM A276 Gr, SS 410	2
18	STEM WASHER	STAINLESS STEEL	ASTM A276 Gr, SS 410	1
19	WASHER	STAINLESS STEEL	ASTM A276 Gr, SS 410	1
20	TOP BOLT	STAINLESS STEEL	----	1
21	STEM NUT	MILD STEEL	----	1
22	BODY BOLT	MILD STEEL	----	60
23	BODY NUT	MILD STEEL	----	60
24	O-RING	RUBBER	EPDM	

Outside Dimensions (mm)

SIZE	DN400	DN450	DN500	DN600
FACE TO FACE (A±3.5)	1100	1200	1250	1450
MAX HEIGHT (H)	790	790	790	790
FLANGE DIA(ØD +4.5/-4.0)	580	640	715	840
BODY ID(Ød)	400	450	500	600
FLANGE PCD(ØK)	525	585	650	770
FLANGE HOLE	16	20	20	20
FLANGE HOLE DIA	31	31	34	37
WHEEL DIA(ØW±5)	450	450	450	450

Balancing Valve DN400 / PN16

Setting	Kv value (m3/h)
3	310
4	898
5	1285
6	1405
7	1890
8	1967
9	2232
10	2865
11	3021
12	3209

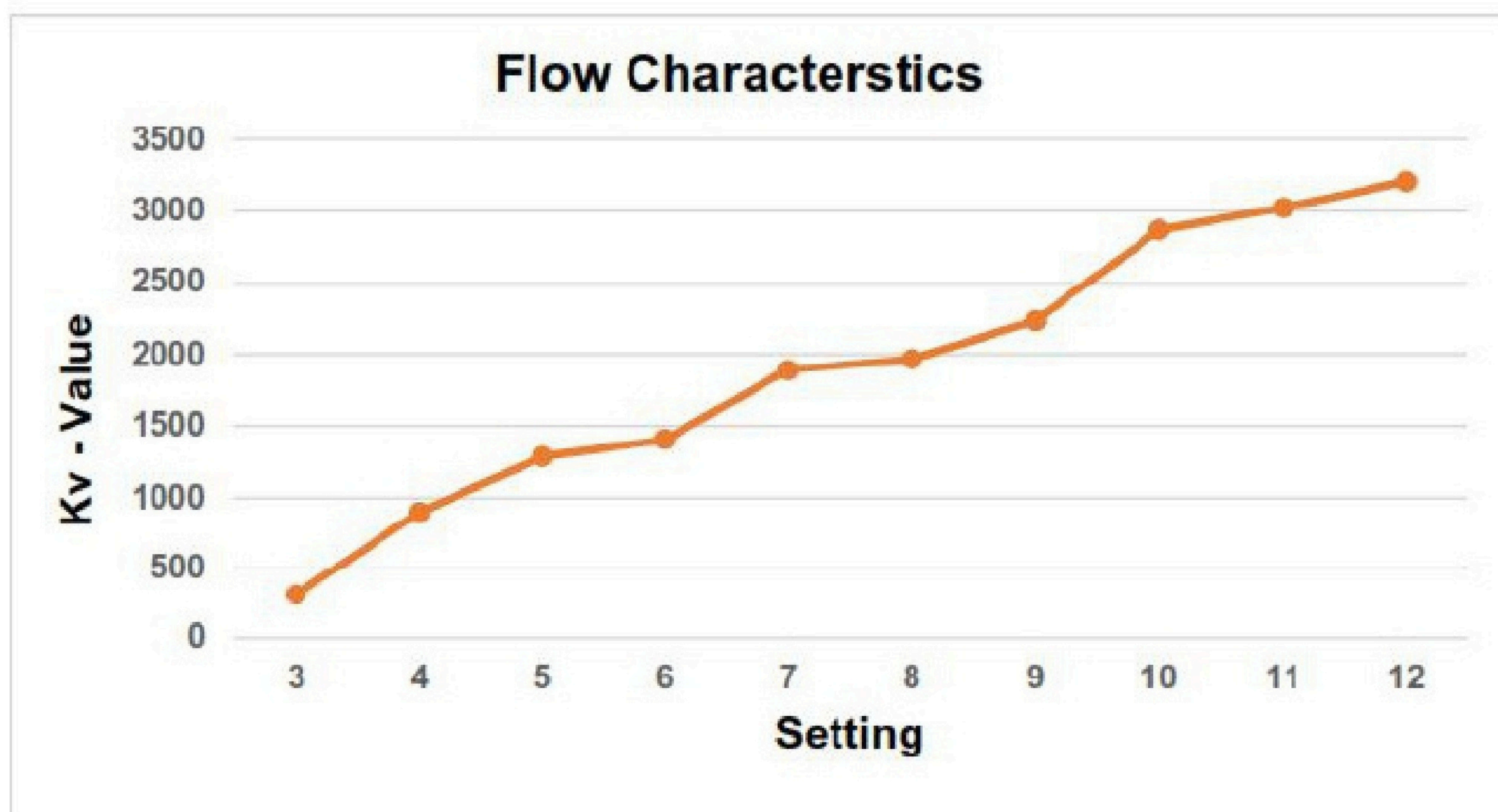

Balancing Valve DN450 / PN16

Setting	Kv value (m3/h)
3	395
4	1087
5	1507
6	1990
7	2172
8	2488
9	2874
10	3345
11	3789
12	4030

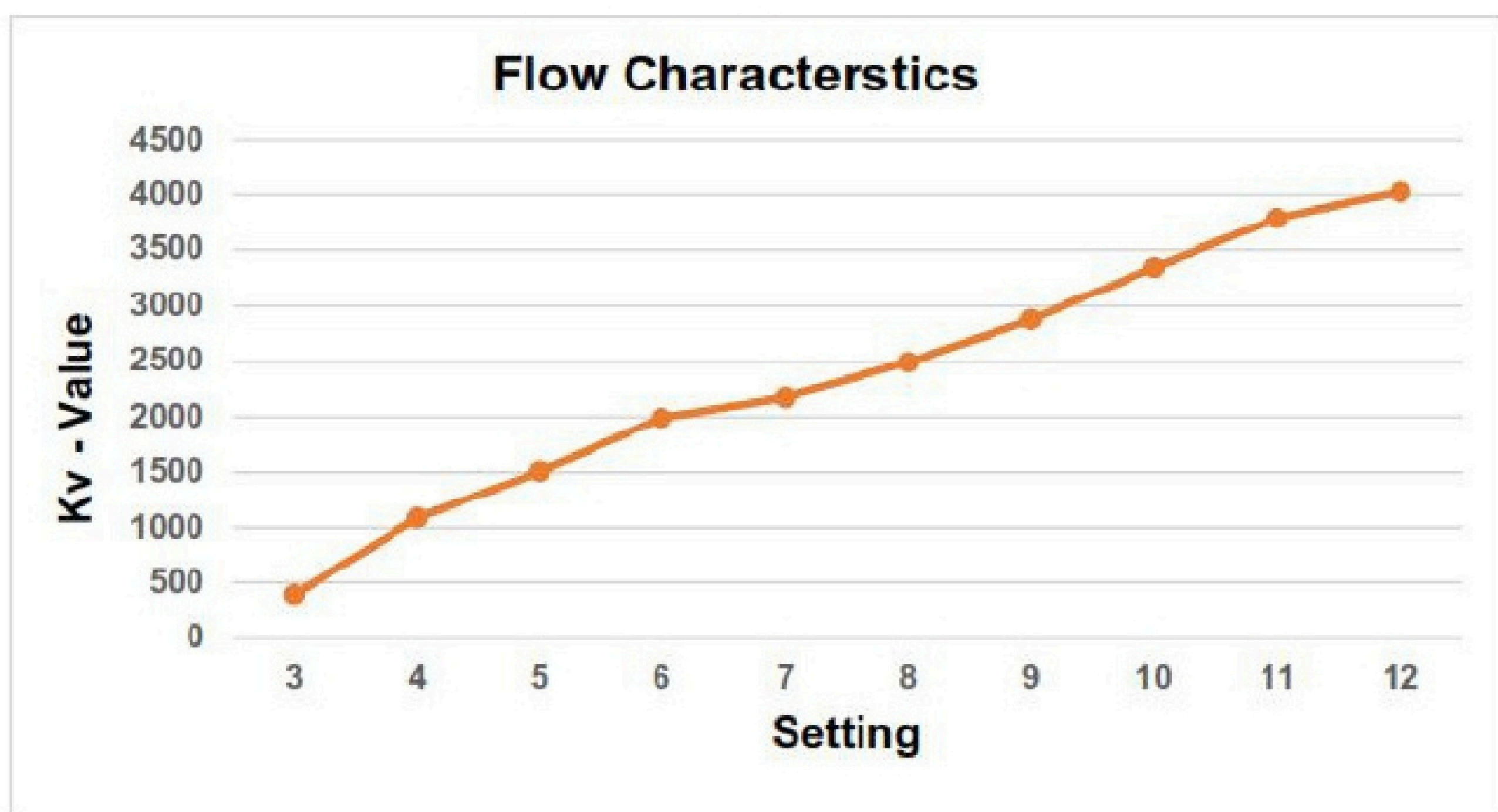

Balancing Valve DN500 / PN16

Setting	Kv value (m3/h)
3	448
4	1120
5	1849
6	2153
7	2690
8	2876
9	3421
10	3987
11	4432
12	4987

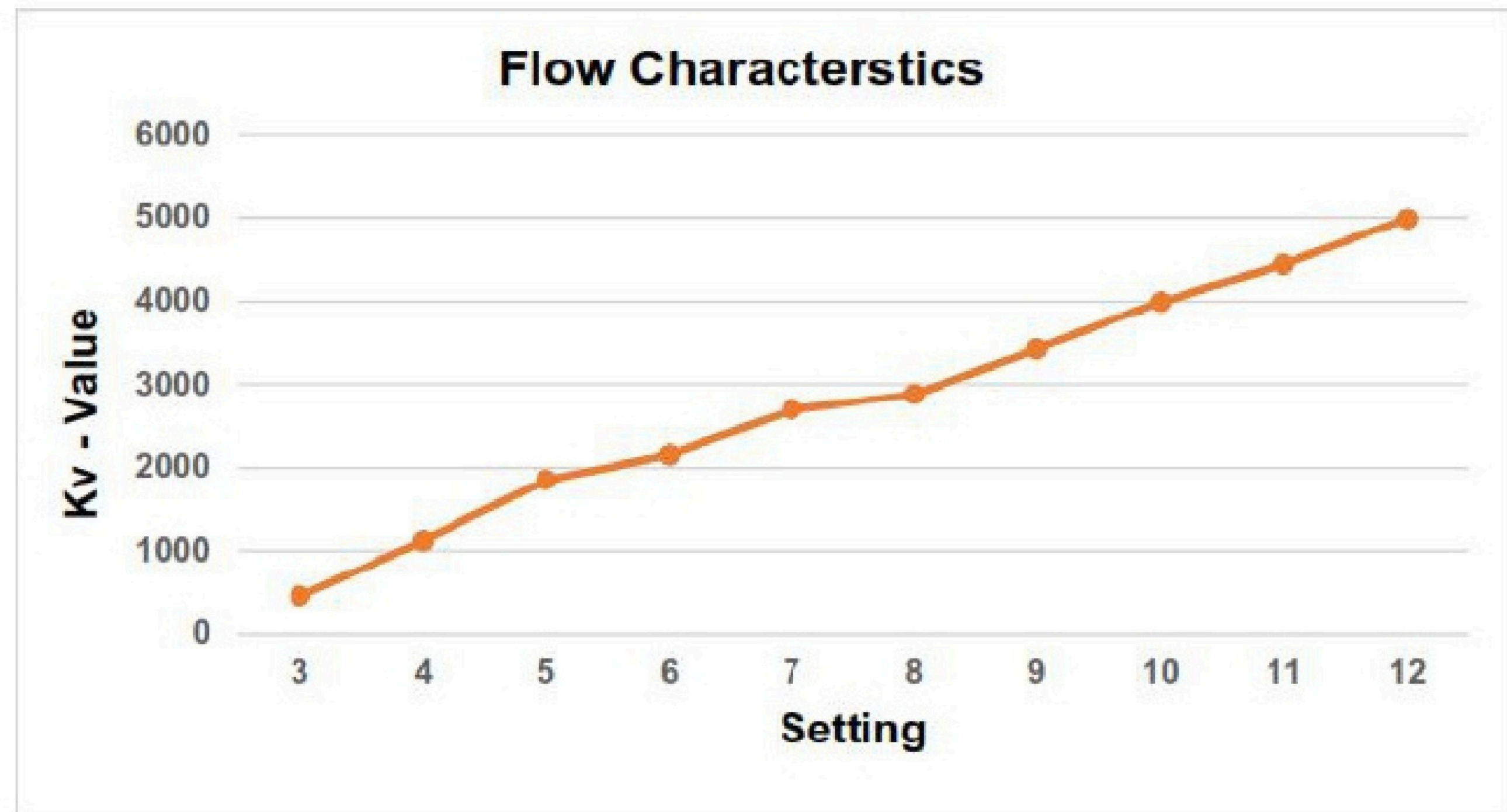

Balancing Valve DN600 / PN16

Setting	Kv value (m3/h)
3	510
4	1453
5	2076
6	2960
7	3612
8	4007
9	4513
10	5002
11	5472
12	5890

