

Manual Balancing Valve Flanged

SKS 130 PN 16

PRODUCT DATA**FEATURES**

- Size: DN50 - DN350
- Body: Cast Iron
- Seat: EPDM
- Connection Type: Flanged End
- Disc: MS/S.S
- Tight shut-off type
- No visible leakage

SPECIFICATIONS

- Medium Temp: -10°C to 110°C
- Medium: Water
- Nominal Pressure: PN16

STANDARDS AND CODES

- Design Standard: BS 7350
- Face to Face: BS:5152
- Flange Std.: ISO 7005-2

HYDROSTATIC TEST PRESSURE

- Shell Test: 24 Bar
- Seat Test: 17.6 Bar

DIRECTION OF FLOW

- Direction of the flow is marked on the valve body by an arrow.

The balancing Valve is designed for double regulating, control and shut off valve with built-in pressure drop measuring facility.

BALANCING VALVE

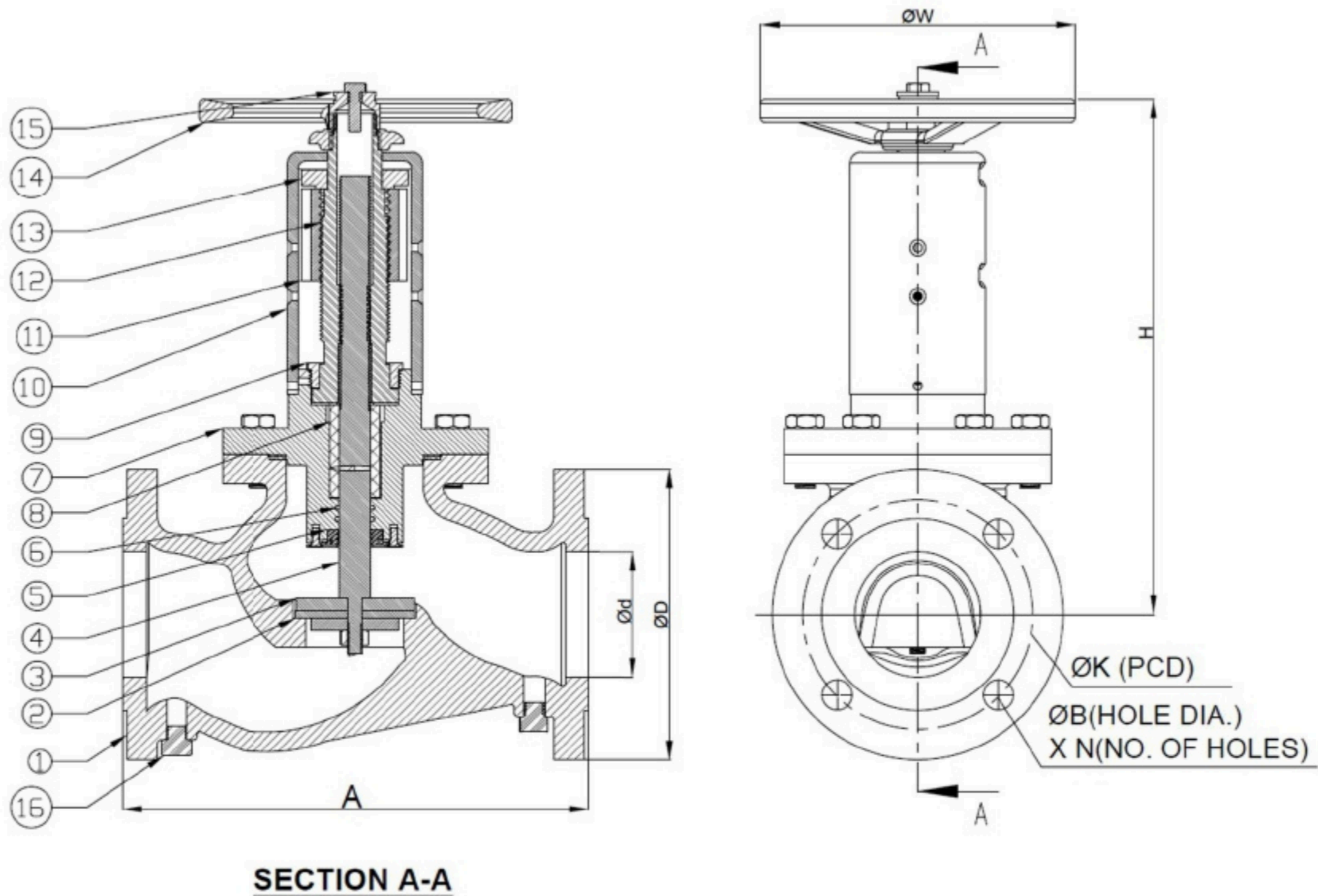

Part Descriptions

PART NO.	NAME	MATERIAL	SPECIFICATION	QTY.
1	BODY	CAST IRON	IS:210 Gr. FG200	1
2	SEAT PACKING	RUBBER	EPDM	1
3	DISC	MILD STEEL/S.S	IS 2062/ ASTM A276 TYPE SS-304 + REPLACEABLE EPDM	1
4	STEM	STAINLESS STEEL	ASTM A276 Gr, SS 410	1
5	SEAL	RUBBER	EPDM	1
6	O-RING	RUBBER	EPDM	3
7	BONNET	CAST IRON	IS:210 Gr. FG200	1
8	GUIDE	NYLON	----	1
9	CHECKNUT	BRASS	----	1
10	COVER	CAST IRON	IS:210 Gr. FG200	1
11	SCALE-1	CAST IRON	IS:210 Gr. FG200	1
12	BALANCING NUT	MILD STEEL	----	1
13	SCALE-2	CAST IRON	IS:210 Gr. FG200	1
14	HANDWHEEL	CAST IRON	IS:210 Gr. FG200	1
15	NUT	CAST IRON	IS:210 Gr. FG200	1
16	PLUG	MILD STEEL	----	2
17	NAMEPLATE	ALUMINIUM	----	1

Outside Dimensions (mm)

SIZE	50	65	80	100	125	150	200	250	300	350
FACE TO FACE (A±3.5)	230	290	310	350	400	480	600	730	850	980
MAX HEIGHT (H)	350	350	365	375	425	425	500	500	600	600
BODY ID (Ød)	50	65	80	100	125	150	200	250	300	350
FLANGE OD (ØD +4.5/-4.0)	165	185	200	220	250	285	340	405	460	520
FLANGE PCD (ØK)	125	145	160	180	210	240	295	355	410	470
NO. OF HOLES(N)	4	4	8	8	8	8	12	12	12	16
FLANGE HOLE DIA(ØB)	19	19	19	19	19	23	23	28	28	28
WHEEL DIA (ØW±5)	200	200	200	200	300	300	300	300	300	300

