

## PRESSURE REDUCING VALVE

# SKS V1

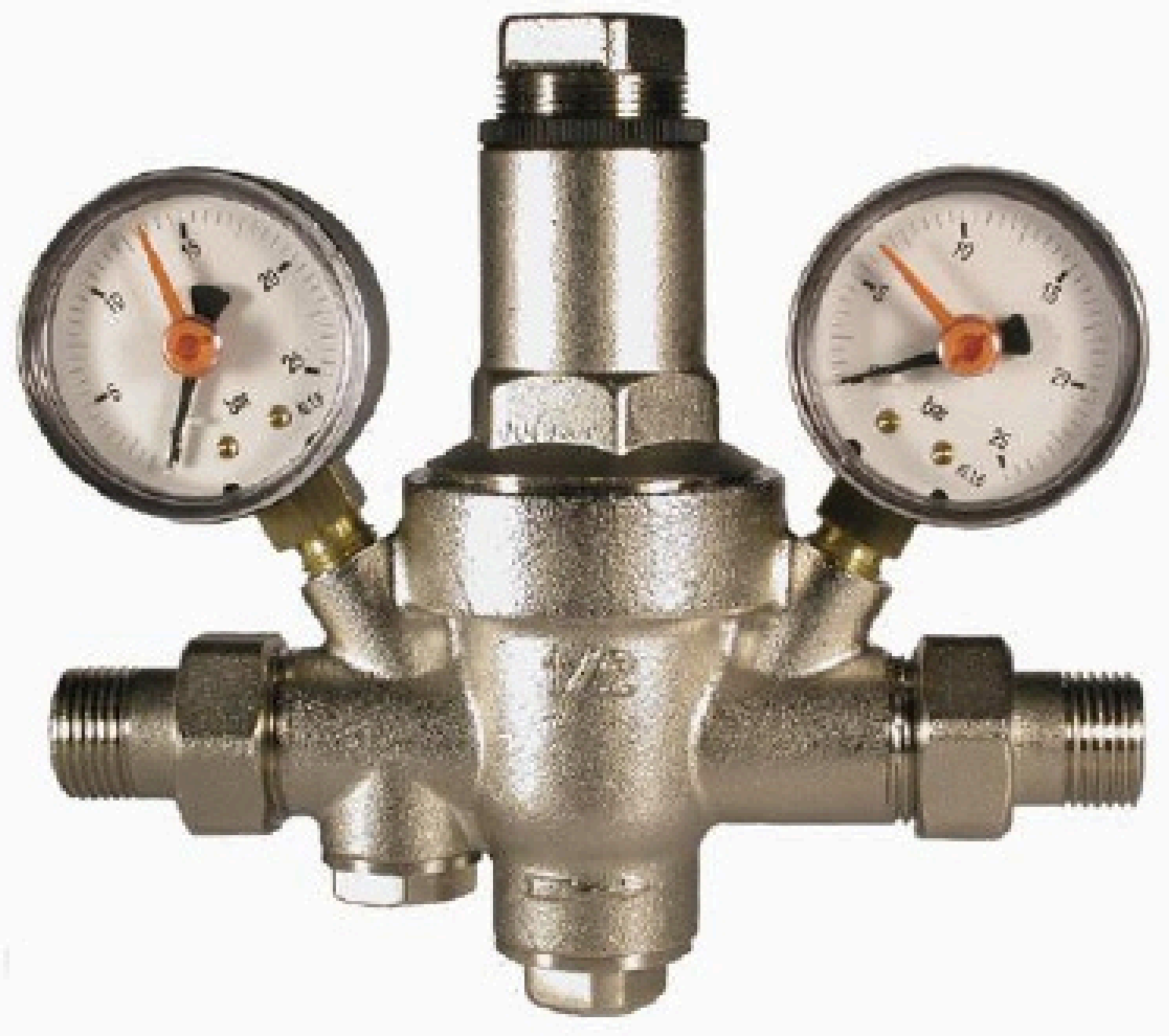

- Direct acting brass pressure reducing valve;
- Membrane operating;
- Built in inlet filter;
- PN 25;
- Adjustable outlet pressure between 0,5 and 7 bar;
- Gauge connection on inlet and outlet;
- Pressure compensation system;
- M-M union connections;
- Max temperature of use 80° C;

### FIELDS:

The pressure reducing valves series SKS V1 are suitable for reduction and control of pressure in plants with the following characteristics:

Max inlet pressure:	<b>25 bar</b>
Field of action (outlet pressure):	<b>0,5 - 7 bar</b>
Max temperature of use:	<b>80° C</b>
Threading of connection:	<b>ISO 228</b>
Tested according to rules:	<b>DIN EN 1567</b>
Suitable fluids:	<b>Water</b>
Reduction rate :	<b>10 : 1</b>

### MATERIALS:

Metal of the body:	<b>Brass alloy</b>
Metal of the inner parts:	<b>Brass alloy – brass alloy according to 4MS</b>
Seat:	<b>Stainless steel AISI 303</b>
Membrane:	<b>EPDM</b>
O-rings:	<b>NBR 70sh</b>
Flat gaskets:	<b>Fasit Italy</b>
Plastic parts:	<b>Ultradid® A3K (BASF)</b>

**Call:** 011-43177627, 28, 29

**Mail:** [info@sksvaives.com](mailto:info@sksvaives.com)

**Website:** [www.sksvaives.com](http://www.sksvaives.com)

**Office:** B-213, Block B, Industrial Area Phase I,  
Naraina, New Delhi-110028

## MAIN DIMENSIONS OF THE PRESSURE REDUCING VALVES SKS V1

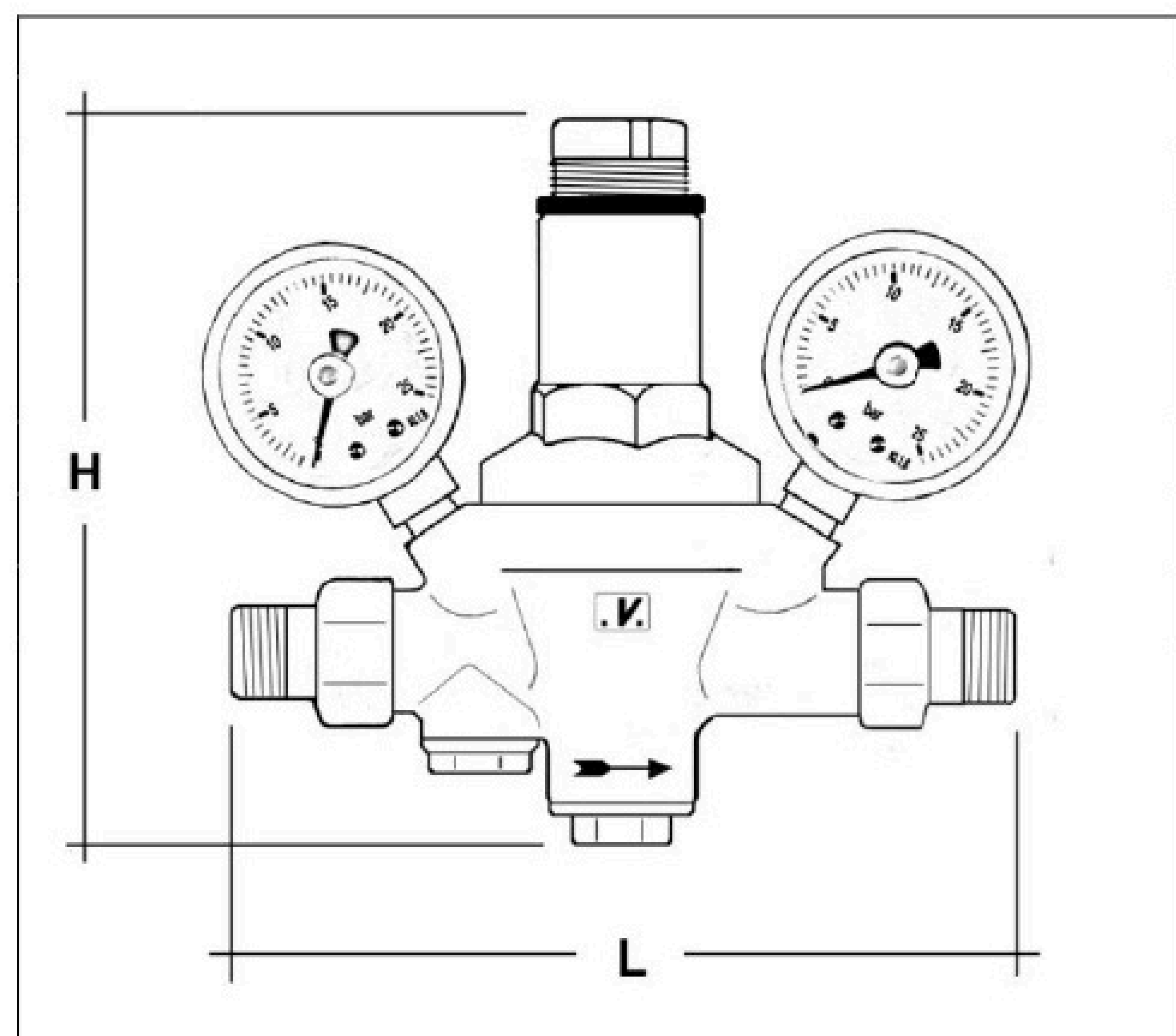

ITEM	DN	H	L
140.12	1/2"	153	165
140.34	3/4"	164	195

## FLOW RATE vs PRESSURE DROP CHART:

DIAGRAMMA DI PORTATA E PERDITA DI CARICO - DISCHARGE AND HEADLOSS DIAGRAM



## BEST HYDRAULIC DISCHARGE OF PRESSURE REDUCERS SKS V1

In order to choose the best pressure reducers for any plant, we suggest to follow the indications mentioned in the underexposed table with the best running pressure of the valves SKS V1.

The values are exposed both in litres/minute and cbm/hour, and indicate the field of use where you can obtain the best functioning, silence and smaller loss of charge of the valves.

MODEL	SIZE	AVERAGE HYDRAULIC DISCHARGE L/min	AVERAGE HYDRAULIC DISCHARGE Cbm/hour
SKS V1	1/2"	14 - 32	0,8 - 1,9
SKS V1	3/4"	18 - 60	1,1 - 3,6

## INSTALLATION OF THE PRESSURE REDUCING VALVE

The pressure reducers SKS V1 don't get the effects – for their functioning – of the gravity force, but in order to optimize the functioning of the built in filter, we suggest to install it horizontally:

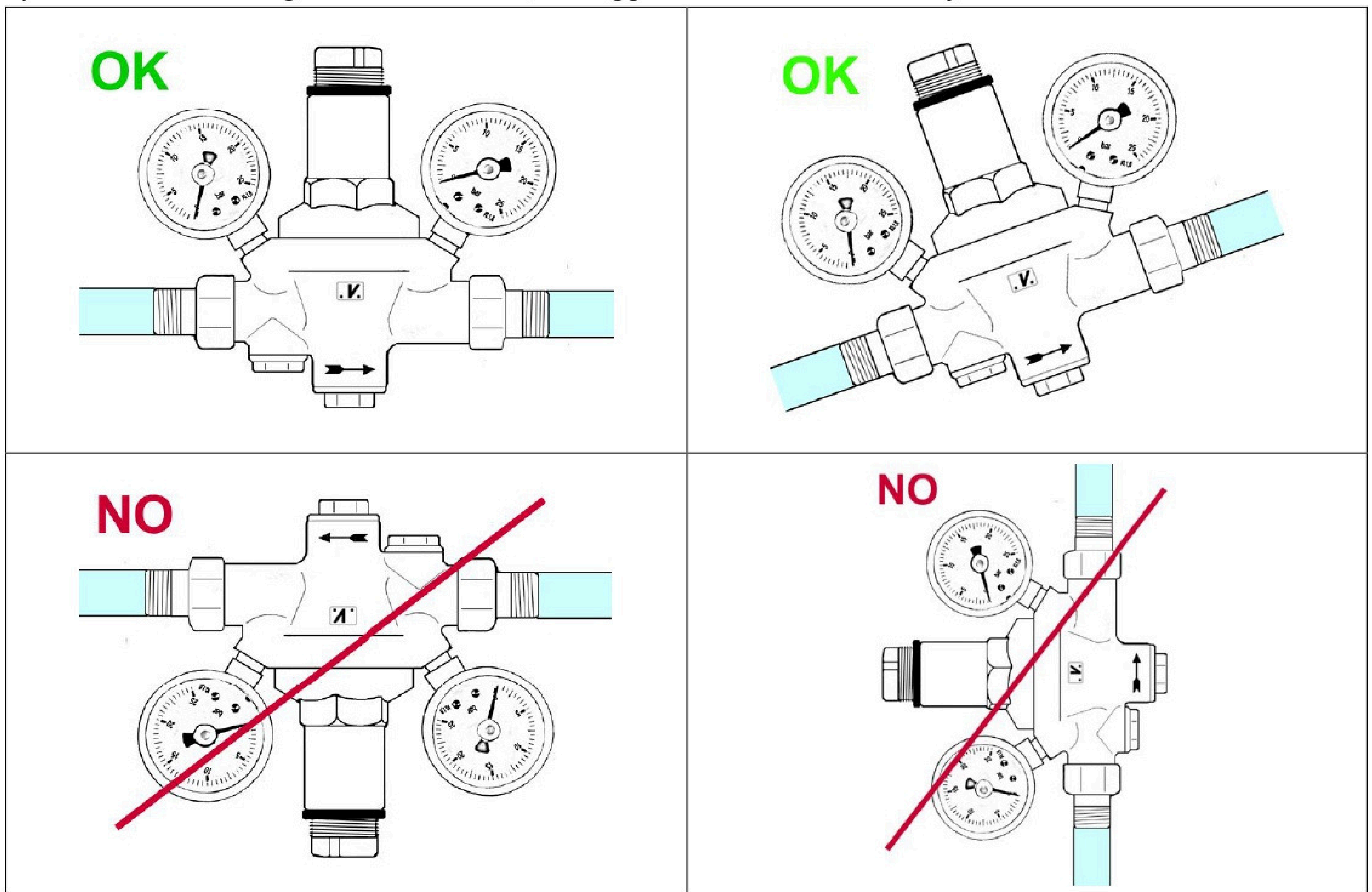

When there is a device which produce or store hot water or pipes are exposed to sudden changes in temperature, an increase of outlet pressure may occur; this event is due to the raise in pressure that follows the temperature rising: an expansion vessel between downstream the pressure reducing valve will avoid this problem.

We recommend moreover to install a Stopshock valve to prevent water hammer which would damage the inner parts of the pressure reducer and other devices in the waterworks.



## CLEANING OF THE BUILT IN FILTER

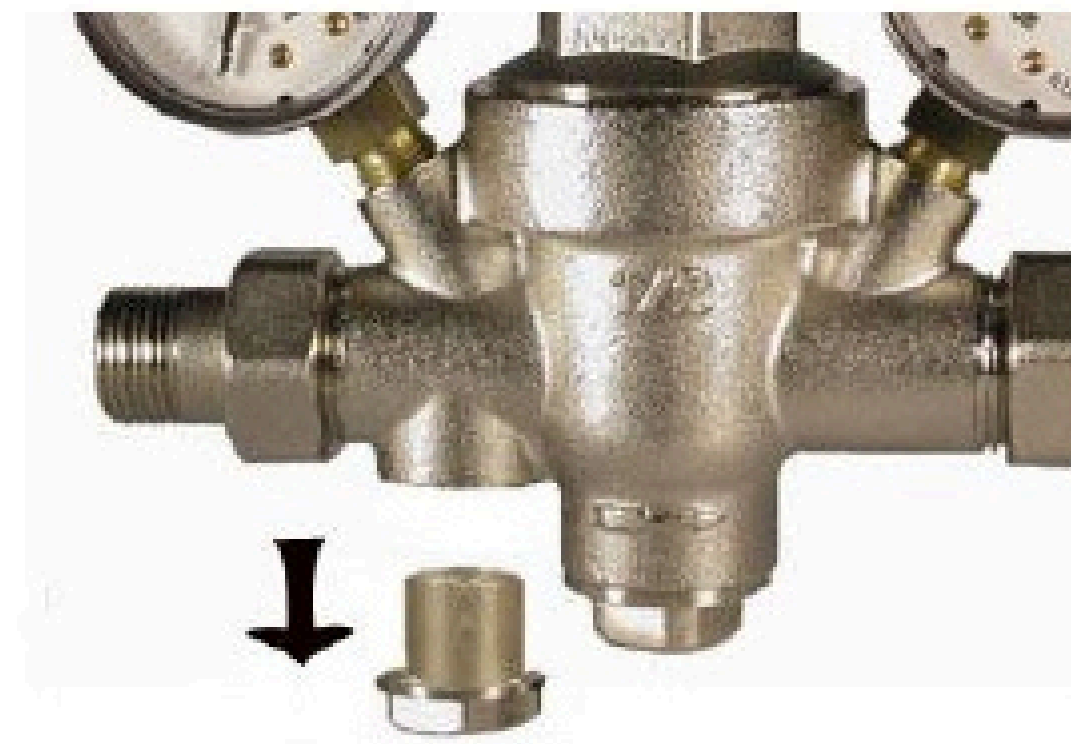
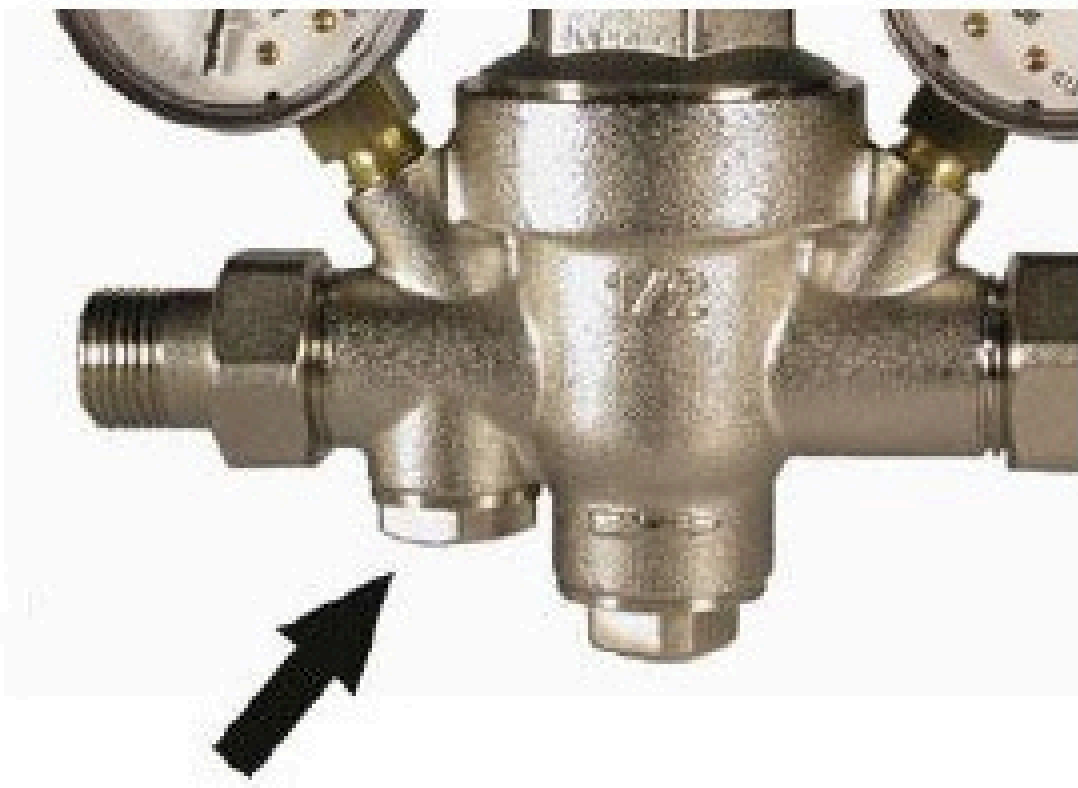

## HOW TO ADJUST THE PRESSURE

All SKS pressure reducers are tested before being packaged; during the proof they are pre-set at the outlet pressure of 3 bars.

Installation or any change of outlet pressure must be performed by qualified personnel.

In order to modify the outlet pressure you should only loosen the fixing ring (1) and turn the spring holder (2) as indicated in the pictures sequence. By turning clockwise the pressure increases, while counter-clockwise the pressure decreases. A right setting should be made while the plant outlet is closed.

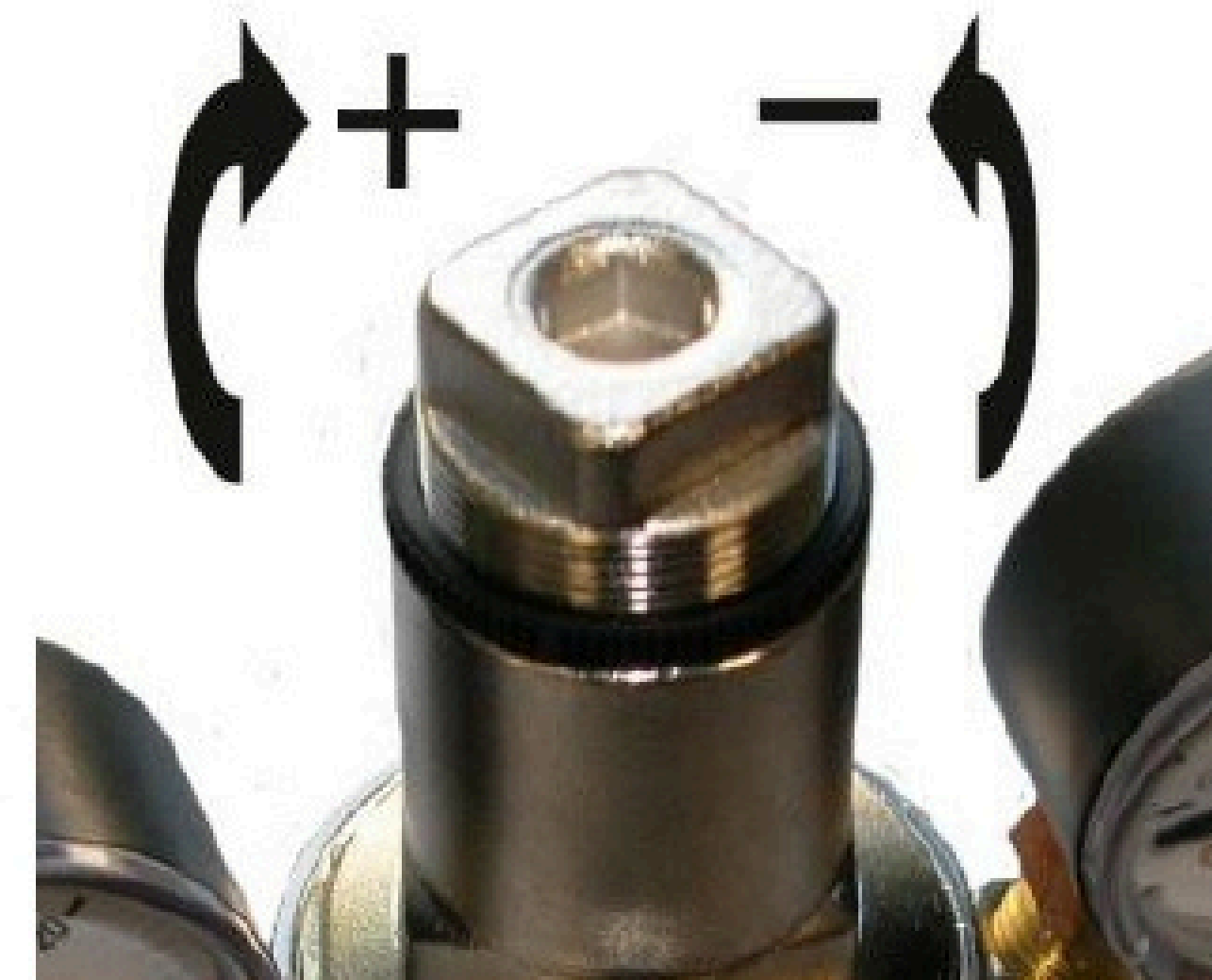
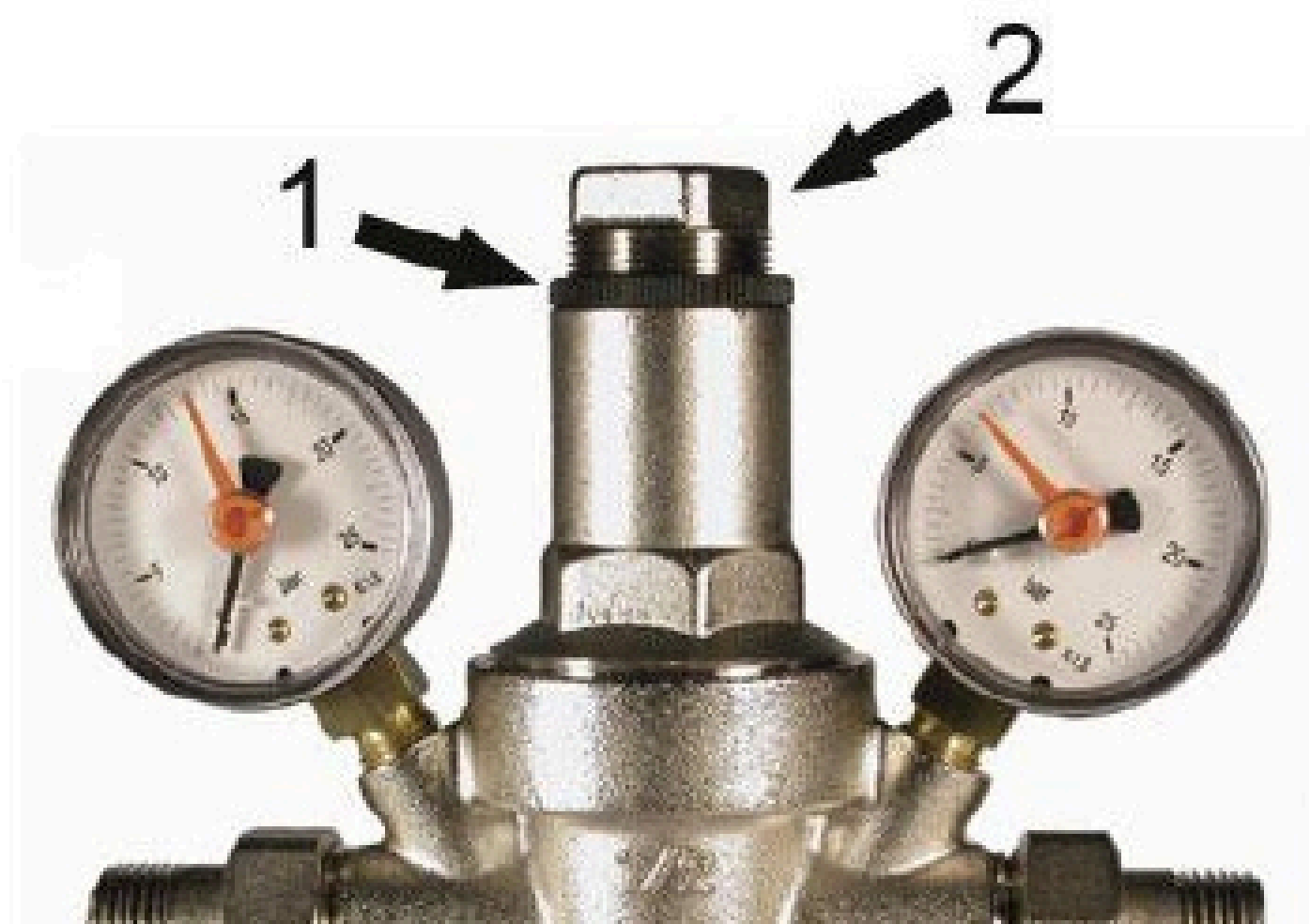

SKS V1 has two gauge connection: please remember to install a 0-25 bar rate pressure gauge on the inlet and a 0-10 bar rate pressure gauge on the outlet connection as shown in the picture.

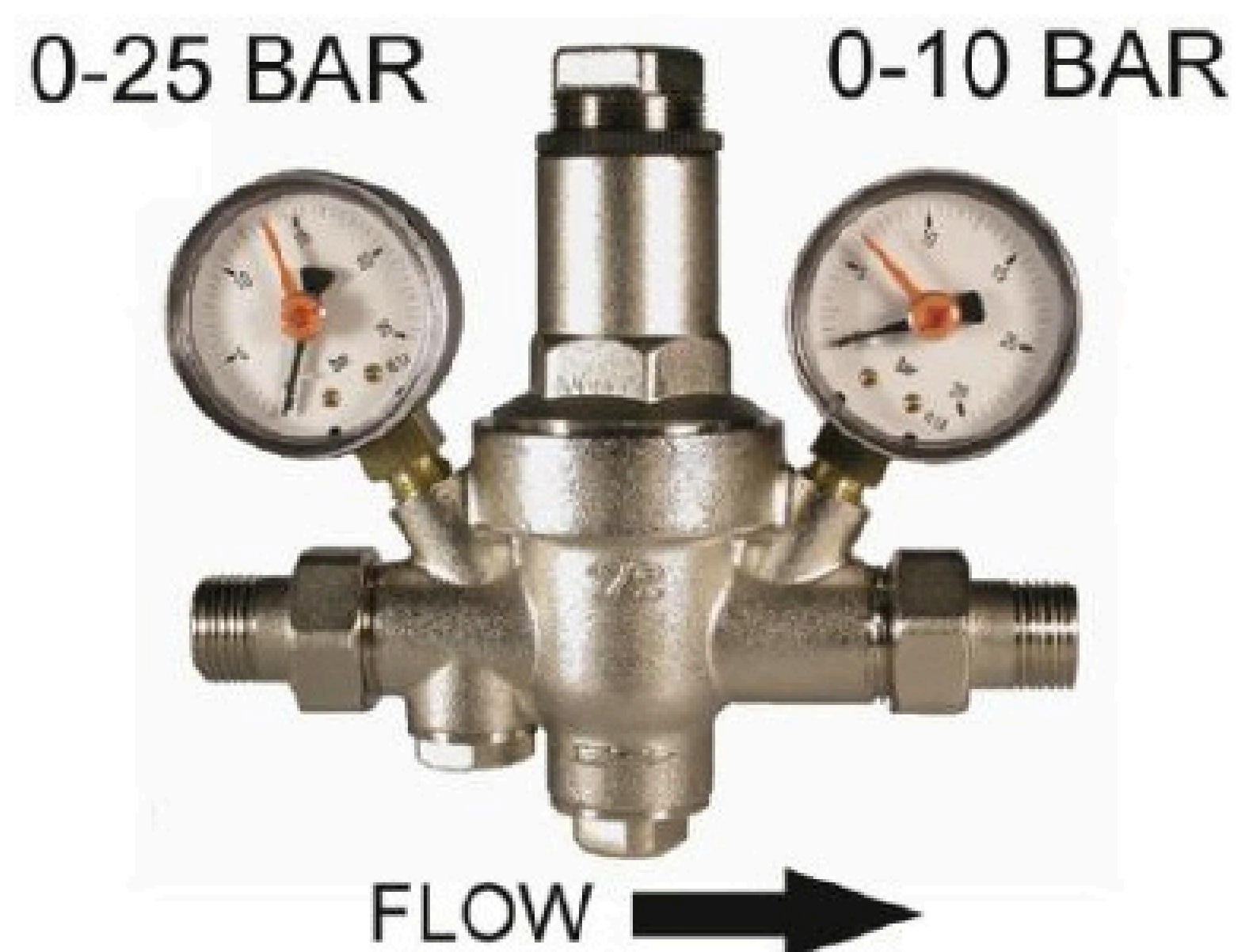

**Call:** 011-43177627, 28, 29  
**Mail:** info@sksvaives.com  
**Website:** www.sksvaives.com  
**Office:** B-213, Block B, Industrial Area Phase I,  
 Naraina, New Delhi-110028