

PT No.	Part Name	Material	QTY.
1	Body	D.I.	1
2	Disc	D.I.	1
3	Liner	EPDM	1
4	Stem	AST A 276, GR SS410	1
5	Bush	PTFE/NYLON	3
6	O-Ring	EPDM	2
7	Fastner	SS/MS	4

Hydrostatic Test Pressure	
Body (kgf/cm ²)	Seat (kgf/cm ²)
24	17.6

SIZE	RATING	VALVE DIMENSIONS								MOUNTING FLANGE DETAIL			
		A	H1	H2	H3	L	ØD	FLANGE STANDARD	FACING	PCD-1	PCD	HOLE DIA	NO. OF HOLES
DN-40	PN20	33	57	125	60	182	40.5	IS:1538/BS:4505	RAISED FACE	126	50	7	4
DN-50	PN20	43	62	120	60	182	50.5	IS:1538/BS:4505	RAISED FACE	145	50	7	4
DN-65	PN20	46	72	130	60	182	65	IS:1538/BS:4505	RAISED FACE	160	50	7	4
DN-80	PN20	46	76	140	60	182	80	IS:1538/BS:4505	RAISED FACE	180	50	7	4
DN-100	PN20	52	95	160	60	182	100	IS:1538/BS:4505	RAISED FACE	210	50	7	4
DN-125	PN20	56	114	170	60	182	123	IS:1538/BS:4505	RAISED FACE	240	70	10	4
DN-150	PN20	56	126	190	60	182	148.5	IS:1538/BS:4505	RAISED FACE	275	70	10	4
DN-200	PN20	60	161	230	60	182	197	IS:1538/BS:4505	RAISED FACE	295	70	10	4
DN-250	PN20	68	215	280	60	182	250.5	IS:1538/BS:4505	RAISED FACE	358	102	12	4
DN-300	PN20	78	230	310	60	182	299.5	IS:1538/BS:4505	RAISED FACE	429	102	12	4

SKS VALVES	
CLIENT	
P.O./ENQ. NO.	
Model :	SKS 117EG
GAD No. :	19BFDT0002-04
Face to Face :	As per ASME B16.10
Valve Type :	BFCONCENTRIC
Operator:	Gearbox
SCALE N.T.S	
SHEET 1 OF 1	

All Dimensions are in MM unless otherwise stated.

Due to Continuous Development we reserve the rights to change in dimensions & Design keeping standard specification same.

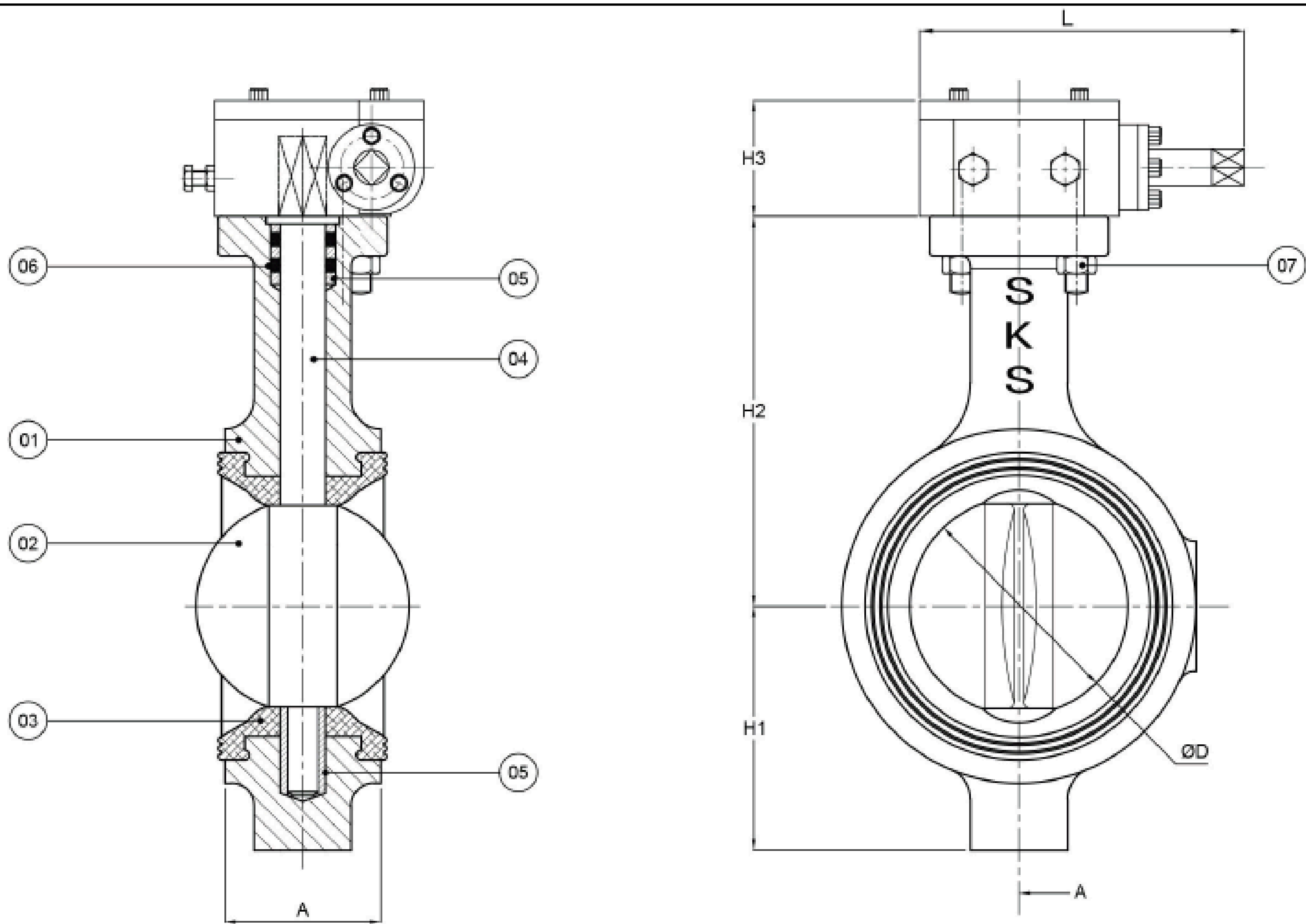

PT No.	PART NAME	MATERIAL
01	BODY	D.I
02	DISC	SS304
03	LINER	EPDM
04	STEM	ASTM A 276, GR SS410
05	BUSH	PTFE / NYLON
06	O-RING	EPDM / NITRILE
07	FASTNER	G.I.

Model No. - SKS117EG

Standard: IS13095

. Outside Dimension (mm)

SIZE	40	50	65	80	100	125	150	200	250	300
A	33.00	43.00	46.00	46.00	52.00	56.00	56.00	60.00	68.00	78.00
H1	57.00	62.00	72.00	76.00	95.00	114.00	126.00	161.00	215.00	230.00
H2	125.00	120.00	130.00	140.00	160.00	170.00	190.00	230.00	280.00	310.00
H3	60.00	60.00	60.00	60.00	60.00	60.00	60.00	60.00	60.00	60.00
L	182.00	182.00	182.00	182.00	182.00	182.00	182.00	182.00	182.00	182.00
Ø D	40.50	50.50	65.00	80.00	100.00	123.00	148.50	197.00	250.50	299.50

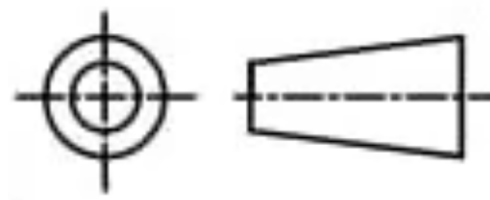

CLIENT	
P.O./ENQ. NO.	
Model :	SKS 117EG
GAD No. :	
Face to Face :	
Valve Type :	
Operator:	

SCALE
N.T.S

SHEET 1 OF 1

Due to Continuous Development we reserve the rights to change in dimensions & Design keeping standard specification same.

All Dimensions are in MM unless otherwise stated.