

DIM. DETAIL :-

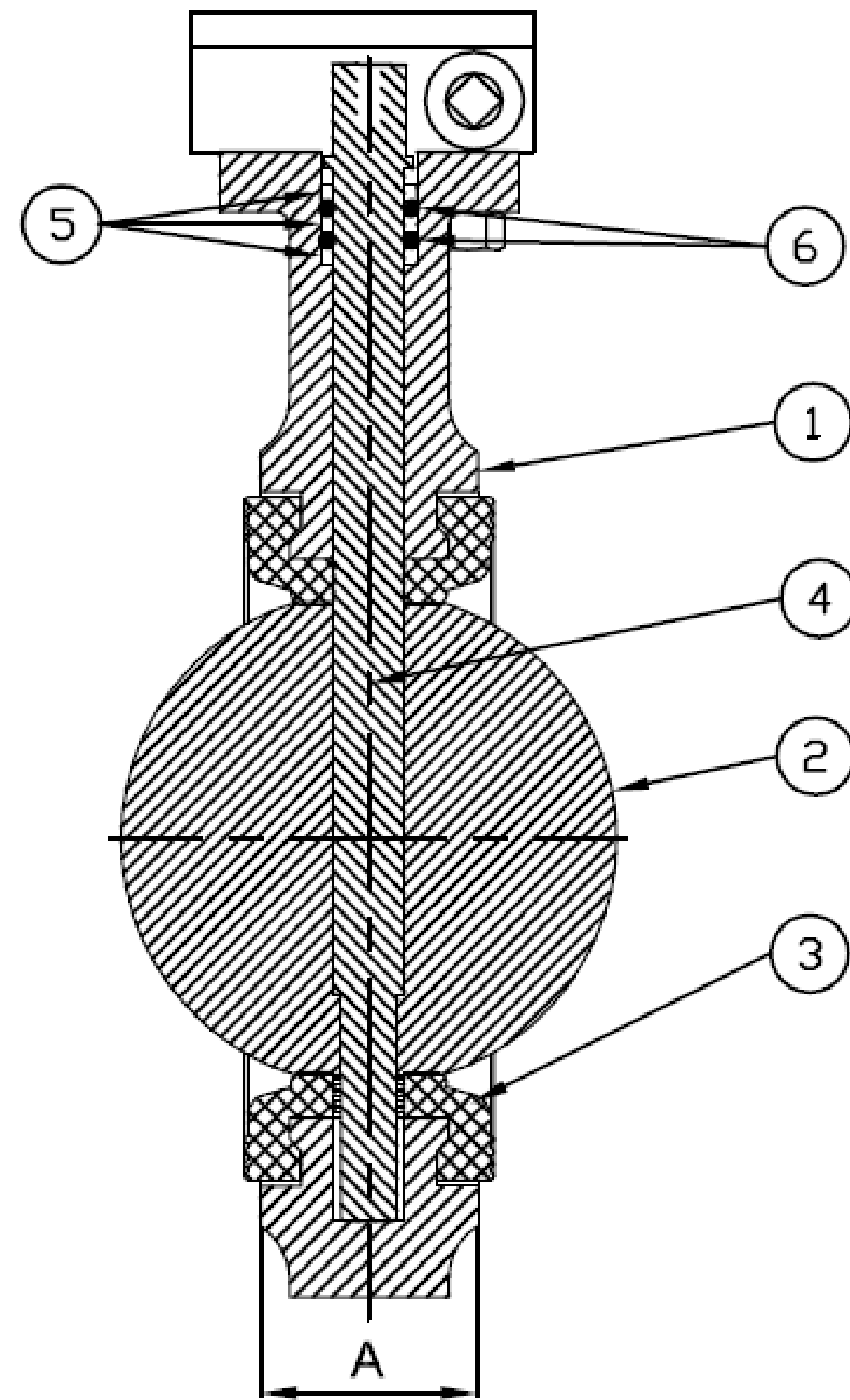

SECTION A-A

PARTS DETAIL :-

S No.	PART NAME	MATERIAL	QTY.
1	BODY	DI	1
2	DISC	SS304	1
3	LINER	EPDM	1
4	STEM	AST A 276 , GR SS410	1
5	BUSH	PTFE / NYLON	3
6	O-RINGS	EPDM	2
7	FASTENER	SS / MS	4

HYDROSTATIC TEST PRESSURE	
BODY (Kgf/cm ²)	SEAT (Kgf/cm ²)
24	17.6

SIZE	RATING	VALVE DIMENSIONS								MOUNTING FLANGE DETAIL			
		A	H1	H2	H3	L	ØD	FLANGE STANDARD	FACING	PCD-1	PCD	HOLE DIA	NO. OF HOLES
DN-40	PN20	33	57	125	60	182	40.5	IS:1538/BS:4505	RAISED FACE	126	50	7	4
DN-50	PN20	43	62	120	60	182	50.5	IS:1538/BS:4505	RAISED FACE	145	50	7	4
DN-65	PN20	46	72	130	60	182	65	IS:1538/BS:4505	RAISED FACE	160	50	7	4
DN-80	PN20	46	76	140	60	182	80	IS:1538/BS:4505	RAISED FACE	180	50	7	4
DN-100	PN20	52	95	160	60	182	100	IS:1538/BS:4505	RAISED FACE	210	50	7	4
DN-125	PN20	56	114	170	60	182	123	IS:1538/BS:4505	RAISED FACE	240	70	10	4
DN-150	PN20	56	126	190	60	182	148.5	IS:1538/BS:4505	RAISED FACE	275	70	10	4
DN-200	PN20	60	161	230	60	182	197	IS:1538/BS:4505	RAISED FACE	295	70	10	4
DN-250	PN20	68	215	280	60	182	250.5	IS:1538/BS:4505	RAISED FACE	358	102	12	4
DN-300	PN20	78	230	310	60	182	299.5	IS:1538/BS:4505	RAISED FACE	429	102	12	4



CLIENT	
P.O./ENQ. NO.	
Model :	SKS 117S4G
GAD No. :	19BFDT0002-03
Face to Face :	
Valve Type :	BFCONCENTRIC
Operator:	Gear Box
SCALE N.T.S	
SHEET 1 OF 1	

Due to Continuous Development we reserve the rights to change in dimensions & Design keeping standard specification same.

All Dimensions are in MM unless otherwise stated.