

Section at 'AA'

PT No.	PART NAME	MATERIAL
01	BODY	D.I
02	SEAT	EPDM
03	PLATES	D.I. (LAPPED) ENP
04	SHAFT	SS304
05	SPRING	SS304
06	O RING	NITRILE
07	PLUG	M. S. (CHROME PLATED)
08	WASHER	STAINLESS STEEL

SIZE	40	50	65	80	100	125	150	200	250	300	350	400	450	500
ØB	52.00	63.00	75.00	92.00	116.00	145.00	169.00	220.00	273.00	324.00	357.00	407.00	457.00	508.00
ØA	80.00	100.00	120.00	130.00	170.00	192.00	215.00	275.00	335.00	405.00	447.00	510.00	545.00	602.00
H	43.00	54.00	54.00	57.00	64.00	70.00	76.00	95.00	108.00	143.00	184.00	191.00	203.00	213.00

All Dimensions are in MM unless otherwise stated.

Due to Continuous Development we reserve the rights to change in dimensions & Design keeping standard specification same.



<b>CLIENT</b>		
<b>P.O./ENQ. NO.</b>		
<b>Model :</b>	SKS 325D	
<b>GAD No. :</b>		
<b>Face to Face :</b>		
<b>Valve Type :</b>		
<b>Operator:</b>		
		<b>SCALE</b> N.T.S
		SHEET 1 OF 1

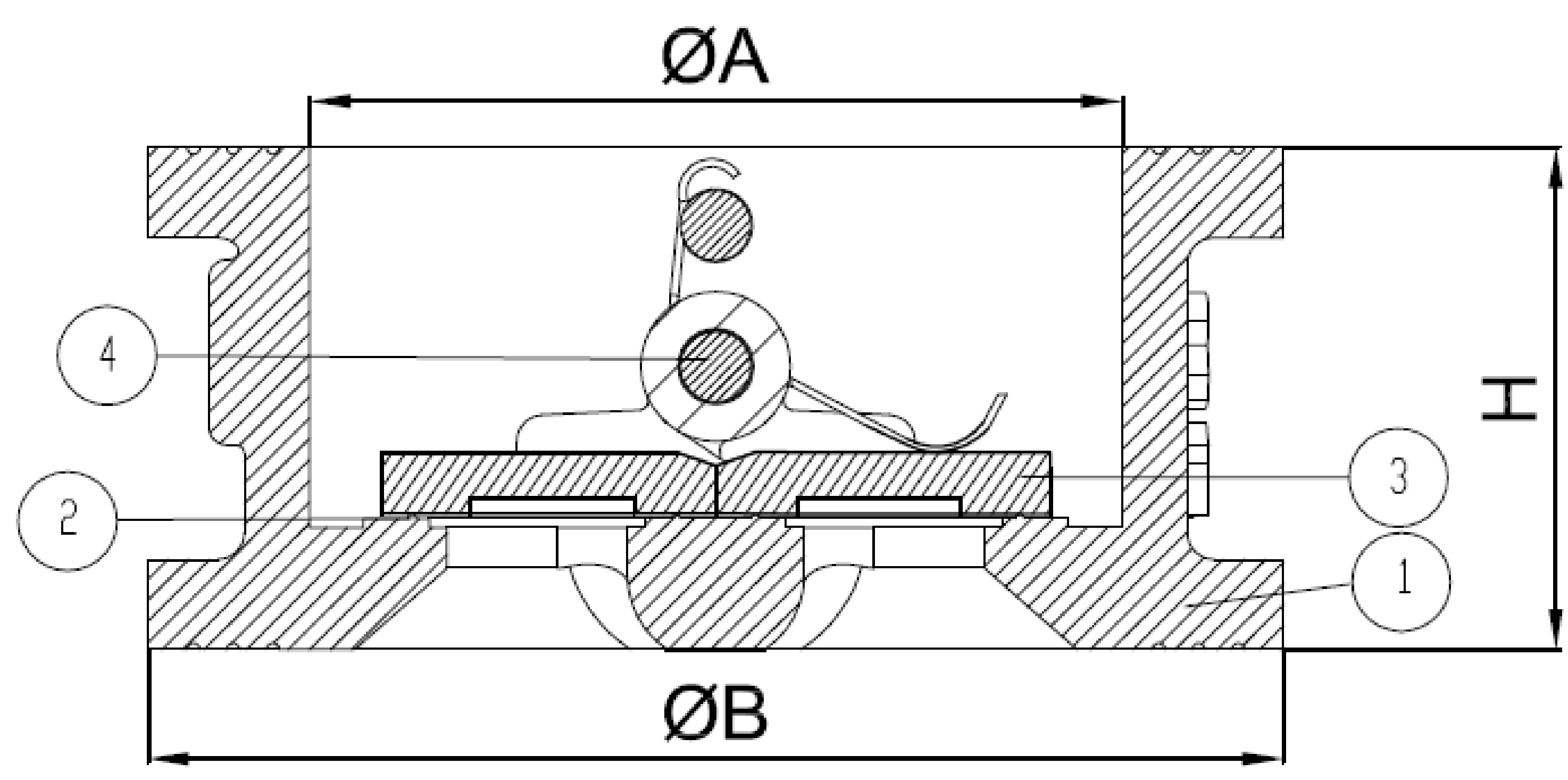
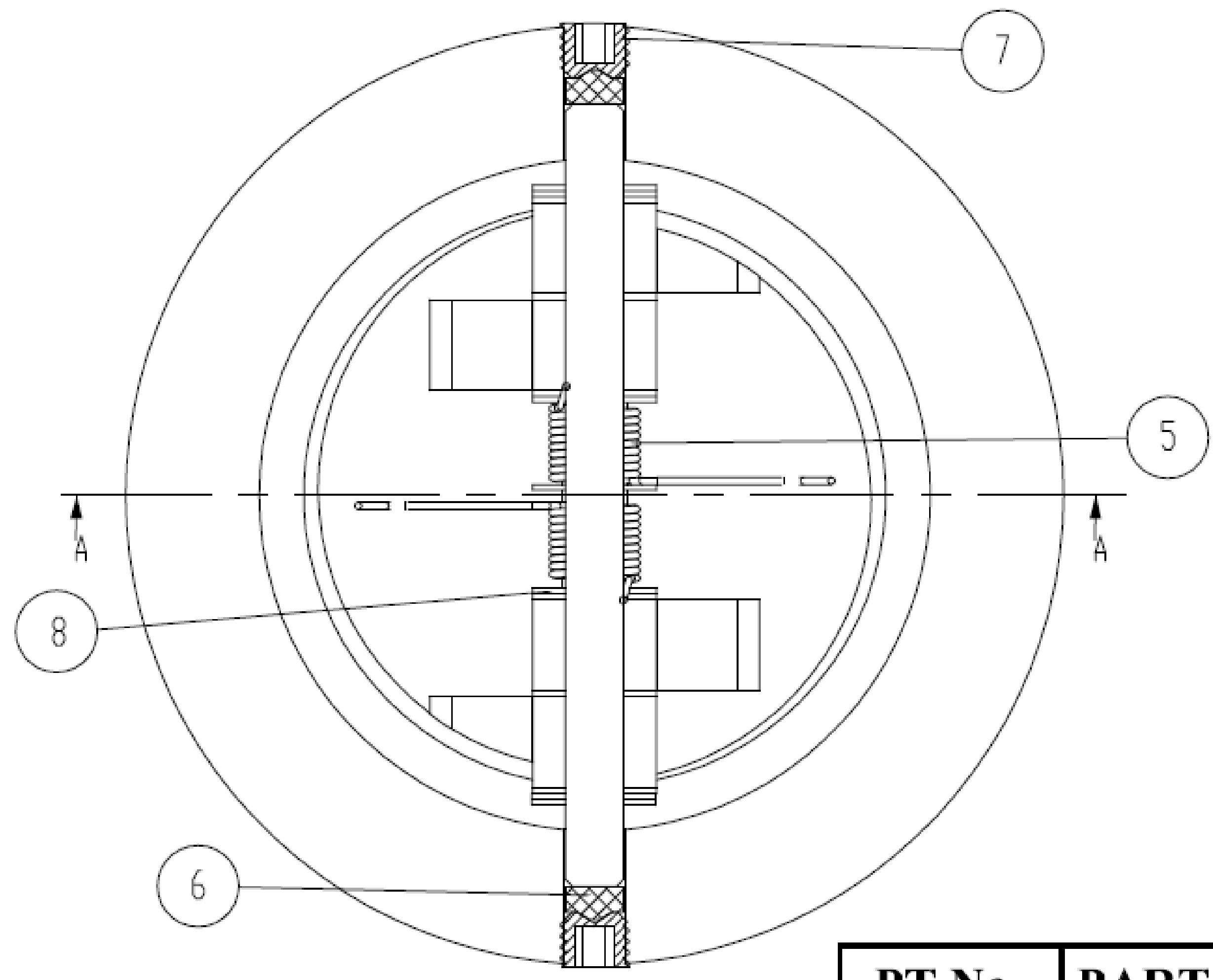

SECTION A-A

PT No.	PART NAME	MATERIAL
1	BODY	D.I
2	SEAT	EPDM
3	PLATES	D.I
4	SHAFT	SS304
5	SPRING	SS304
6	O-RING	NITRILE / EPDM
7	PLUG	M.S. (CROME PLATED)
8	WASHER	STAINLESS STEEL

HYDROSTATIC TEST PRESSURE	
BODY (Kgf/cm <sup>2</sup> )	SEAT (Kgf/cm <sup>2</sup> )
24	17.6



SIZE	RATING	40	50	65	80	100	125	150	200	250	300
ØA	PN25	52	63	75	92	116	145	169	220	273	324
ØB	PN25	80	100	120	130	170	192	215	275	335	405
H	PN25	43	54	54	57	64	70	76	95	108	143

<b>CLIENT</b>		
<b>P.O./ENQ. NO.</b>		
<b>Model :</b>	SKS 325D-1	
<b>GAD No. :</b>	19DPDT0002-02	
<b>Face to Face :</b>		
<b>Valve Type :</b>	Dual Plate Check Valve	
<b>SEAT:</b>	Soft Seated	
		<b>SCALE</b> N.T.S
		SHEET 1 OF 1

All Dimensions are in MM unless otherwise stated.

Due to Continuous Development we reserve the rights to change in dimensions & Design keeping standard specification same.